

# INSTRUMENT

# CG-4D

BEAM LINE

HIGH FLUX ISOTOPE REACTOR

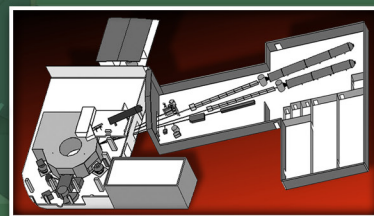

## IMAGINE – QUASI-LAUE SINGLE-CRYSTAL DIFFRACTOMETER

IMAGINE is a state-of-the-art neutron image plate single-crystal diffractometer. It will provide atomic-resolution information on chemical, organic, metallo-organic, and protein single crystals, enabling new understanding of their chemical, physical, and biological structure and function. Research at IMAGINE will benefit communities with interests in pharmaceuticals, minerals and other inorganic crystals, small molecules, molecular organo-metallic crystals and metal-organic frameworks, and molecular crystal structures. It will also enable the neutron crystal structure of oligo-nucleotides and proteins to be determined at or near atomic resolutions (1.5 Å).

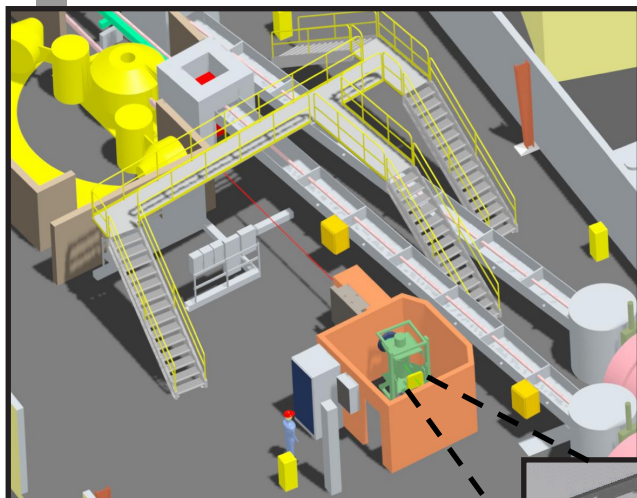

Cold neutron guide hall.

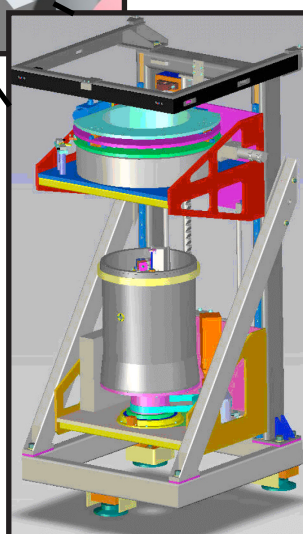

MAATEL

The IMAGINE team welcomes discussion and interaction with the scientific community throughout the installation and commissioning phase of the instrument and is excited to start working with the community to build an excellent education and science program. The acquisition and installation of IMAGINE is supported by the National Science Foundation.

### APPLICATIONS

#### Protein Structure-Function

- Hydrogen atoms in proteins
- Enzymology
- Ligand complexes
- Drug design

#### Supramolecular Crystallography

- Single-molecule magnets
- Metal-organic frameworks
- Polyoxometalates

#### Materials Under Extreme Environments

- 1 Mb and cryogenic temperatures
- Phase transitions
- Magnetic transitions

### SPECIFICATIONS

Flux	$5 \times 10^9$ n/s/cm <sup>2</sup>
Cross section	10 x 19 mm
wavelengths minimum	2, 3, 3.5 Å
wavelengths maximum	3, 4, 4.5 Å
Detector	Neutron image plate
Detector size	1200 x 450 mm
Pixel size	125, 250, 500 μm
Sample-to-detector distance	200 mm
Goniometer	Single Phi rotation axis
Cryogenics	
High-temperature furnaces	
Pressure cells	

Status: In commissioning



The acquisition and installation of IMAGINE is supported by the National Science Foundation. Award to Tibor Koritsanszky, Middle Tennessee State University.

### FOR MORE INFORMATION, CONTACT

Instrument Scientist: Flora Meilleur, [meilleurf@ornl.gov](mailto:meilleurf@ornl.gov), 865.241.2897

[neutrons.ornl.gov/cg4c](http://neutrons.ornl.gov/cg4c)



February 2012